



RAM

2017

**OWNER'S MANUAL
SUPPLEMENT**

**RAM TRUCK 2500
COMPRESSED NATURAL GAS**

VEHICLES SOLD IN CANADA

With respect to any Vehicles Sold in Canada, the name FCA US LLC shall be deemed to be deleted and the name FCA Canada Inc. used in substitution therefore.

DRIVING AND ALCOHOL

Drunken driving is one of the most frequent causes of accidents.

Your driving ability can be seriously impaired with blood alcohol levels far below the legal minimum. If you are drinking, don't drive. Ride with a designated non-drinking driver, call a cab, a friend, or use public transportation.

WARNING!

Driving after drinking can lead to an accident. Your perceptions are less sharp, your reflexes are slower, and your judgment is impaired when you have been drinking. Never drink and then drive.

This manual illustrates and describes the operation of features and equipment that are either standard or optional on this vehicle. This manual may also include a description of features and equipment that are no longer available or were not ordered on this vehicle. Please disregard any features and equipment described in this manual that are not on this vehicle.

FCA US LLC reserves the right to make changes in design and specifications, and/or make additions to or improvements to its products without imposing any obligation upon itself to install them on products previously manufactured.

Copyright © 2016 FCA US LLC



TABLE OF CONTENTS

SECTION

PAGE

1	INTRODUCTION	3	1
2	THINGS TO KNOW BEFORE STARTING YOUR VEHICLE	5	2
3	UNDERSTANDING YOUR INSTRUMENT PANEL	11	3
4	STARTING AND OPERATING	59	4
5	MAINTAINING YOUR VEHICLE	65	5
6	MAINTENANCE SCHEDULE	69	6
7	INDEX	71	7

INTRODUCTION

CONTENTS

■ INTRODUCTION. 4

INTRODUCTION

This booklet is a supplement to the Ram 1500/2500/3500 Owner's Manual. It contains information relative to the Compressed Natural Gas equipment installed on this vehicle by the manufacturer. You are urged to read this publication and the Owner's Manual carefully.

Following the instructions and recommendations provided herein will help assure safe and reliable operation of your vehicle. After you have read the booklet it should be stored in the vehicle for convenient reference and remain with the vehicle when sold.

When it comes to service, remember that your authorized dealer knows your vehicle best, has factory-trained technicians and genuine MOPAR® parts, and cares about your satisfaction.

THINGS TO KNOW BEFORE STARTING YOUR VEHICLE

CONTENTS

■ GENERAL INFORMATION	6	■ MANUAL SHUT OFF VALVE	8
■ SAFETY WARNINGS	6		

GENERAL INFORMATION

Your vehicle is designed to operate on gasoline or Compressed Natural Gas (CNG). Compressed Natural Gas is made up primarily of methane and is in a gaseous state at all times.

The manufacturer's built vehicles equipped with compressed natural gas fueled engines are identified by the character T in the eighth (engine) position of the Vehicle Identification Number (V.I.N.).

SAFETY WARNINGS

Natural gas is safe and reliable, when used properly. For safe operation of your vehicle, observe the following precautions:

WARNING!

- Your vehicle fuel system has a maximum capacity of 3,600 pounds per square inch gauge (24.8 MPa) compensated to a temperature of 70° F (21° C). The vehicle should only be filled from refueling equipment incorporating temperature compensation to 70° F (21° C). Exceeding the fuel system capacity may result in fuel system damage and possibly cause injury.
- Do not attempt to force open or tamper with the fuel fill receptacle. A sudden release of natural gas may occur, possibly causing injury.
- Natural gas contains an odorant additive and persistent natural gas odor may indicate a leak. If a persistent natural odor is detected, the cause should be located and corrected immediately by a qualified technician.

(Continued)

WARNING! (Continued)

- Do not park or service your vehicle near any source of excessive heat or open flame. Never use a paint oven to cure any paint repairs. The natural gas storage containers on this vehicle are equipped with pressure relief devices which vent at 230° F (110° C).
- Do not paint or under coat any natural gas fuel system components. Unlike gasoline, a compressed natural gas fuel system is under very high pressure even when the engine is not running. To avoid risk of personal injury, any repair to the fuel system should be performed by a qualified technician.
- Natural gas vapors at atmospheric pressure are lighter than air and will rise and disperse in open areas. In enclosed areas, natural gas vapor may collect and form a combustible mixture. If the vehicle is routinely placed in an enclosed area, the area should be provided with adequate ventilation and/or a natural gas detection system. For long term storage, the manual shutoff valve and individual container valves should be closed.

(Continued)

WARNING! (Continued)

- When a vehicle is involved in an accident which has or may have caused damage to the natural gas fuel system, the system must be inspected and pressure tested by a qualified technician before returning the vehicle to service.
- Any fuel system component, including the containers, that has been subjected to fire may not be returned to service due to reduced pressure capability.

8 THINGS TO KNOW BEFORE STARTING YOUR VEHICLE

MANUAL SHUT OFF VALVE

The manual one-quarter turn shut off valve is located inside the protective cover for the tanks. It's location is identified by a label on the top of the cover. This valve isolates the fuel containers from the rest of the fuel system.



Manual Shut Off Valve Access Door

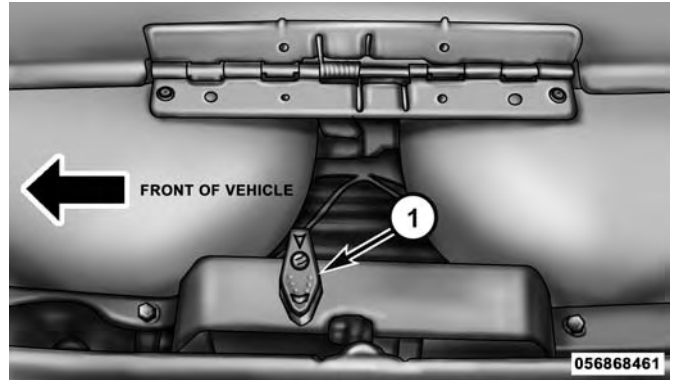

Manual Shut Off Valve

1 — Valve Off

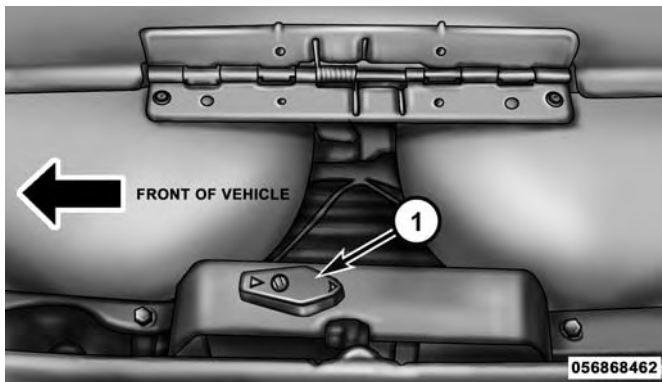

1 — Valve On

UNDERSTANDING YOUR INSTRUMENT PANEL

CONTENTS

■ INSTRUMENT CLUSTER	12	■ INSTRUMENT CLUSTER DISPLAY	42
■ WARNING AND INDICATOR LIGHTS	16	□ Instrument Cluster Display Controls	43
□ Red Telltale Indicator Lights	17	□ Instrument Cluster Display Screens	45
□ Yellow Telltale Indicator Lights	24	□ Oil Life Reset	47
□ Green Telltale Indicator Lights	38	□ Instrument Cluster Display Selectable Menu Items	48
□ White Telltale Indicator Lights	40	□ Instrument Cluster Display Messages	54
□ Blue Telltale Indicator Lights	42	□ Instrument Cluster Display Controls	57

INSTRUMENT CLUSTER

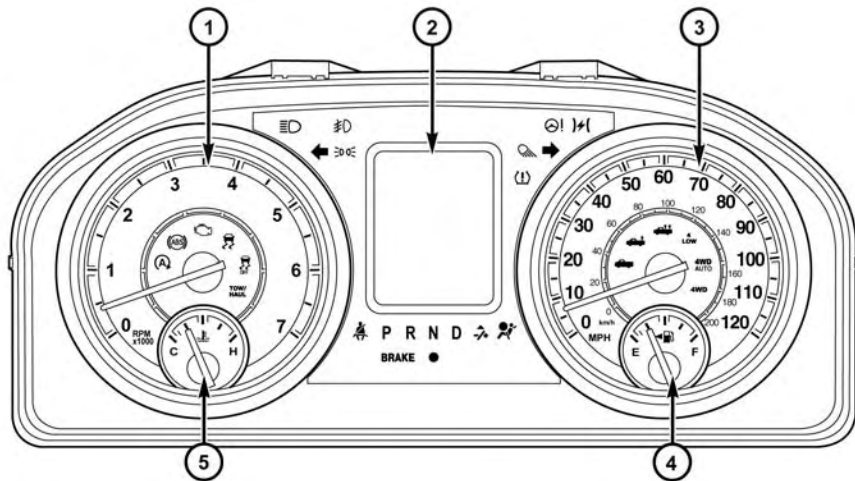

0403077349

Base Instrument Clusters

1. Tachometer
 - Indicates the engine speed in revolutions per minute (RPM x 1000).
2. Instrument Cluster Display
 - When the appropriate conditions exist, this display shows the Instrument Cluster Display messages. Refer to “Instrument Cluster Display” in “Understanding Your Instrument Panel” for further information.
3. Speedometer
 - Indicates vehicle speed.
4. Fuel Gauge
 - The pointer shows the level of fuel in the fuel tank when the ignition is in the ON/RUN position.
 -  The fuel pump symbol points to the side of the vehicle where the fuel door is located.
5. Temperature Gauge
 - The temperature gauge shows engine coolant temperature. Any reading within the normal range indicates that the engine cooling system is operating satisfactorily.

- The gauge pointer will likely indicate a higher temperature when driving in hot weather, up mountain grades, or when towing a trailer. It should not be allowed to exceed the upper limits of the normal operating range.

WARNING!

A hot engine cooling system is dangerous. You or others could be badly burned by steam or boiling coolant. You may want to call an authorized dealer for service if your vehicle overheats. If you decide to look under the hood yourself, see “Maintaining Your Vehicle”. Follow the warnings under the Cooling System Pressure Cap paragraph.

CAUTION!

Driving with a hot engine cooling system could damage your vehicle. If the temperature gauge reads “H” pull over and stop the vehicle. Idle the vehicle with the air conditioner turned off until the pointer drops back into the normal range. If the pointer remains on the “H”, turn the engine off immediately and call an authorized dealer for service.

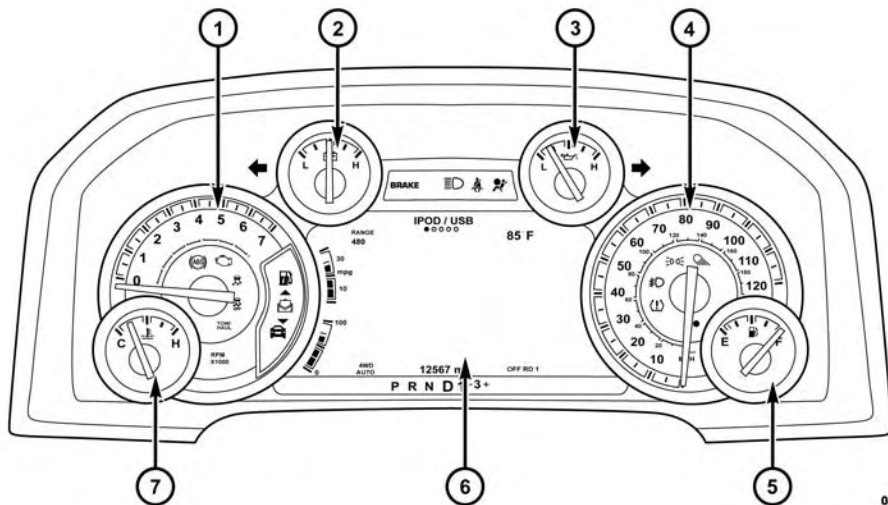

0403077350

Premium Instrument Clusters

1. Tachometer

- Indicates the engine speed in revolutions per minute (RPM x 1000).

2. Voltmeter

- When the engine is running, the gauge indicates the electrical system voltage. The pointer should stay within the normal range if the battery is charged. If the pointer moves to either extreme left or right and remains there during normal driving, the electrical system should be serviced.

NOTE: The voltmeter may show a gauge fluctuation at various engine temperatures. This cycling operation is caused by the post-heat cycle of the intake manifold heater system. The number of cycles and the length of the cycling operation is controlled by the engine control module. Post-heat operation can run for several minutes, and then the electrical system and voltmeter needle will stabilize.

3. Oil Pressure Gauge

- The pointer should always indicate some oil pressure when the engine is running. A continuous high or low reading under normal driving conditions may indicate a lubrication system malfunction. Immediate service should be obtained from an authorized dealer.

4. Speedometer

- Indicates vehicle speed.

5. Fuel Gauge

- The pointer shows the level of fuel in the fuel tank when the ignition is in the ON/RUN position.
-  The fuel pump symbol points to the side of the vehicle where the fuel door is located.

6. Instrument Cluster Display

- When the appropriate conditions exist, this display shows the Instrument Cluster Display messages. Refer to “Instrument Cluster Display” in “Understanding Your Instrument Panel” for further information.

7. Temperature Gauge

- The temperature gauge shows engine coolant temperature. Any reading within the normal range indicates that the engine cooling system is operating satisfactorily.
- The gauge pointer will likely indicate a higher temperature when driving in hot weather, up mountain grades, or when towing a trailer. It should not be allowed to exceed the upper limits of the normal operating range.

WARNING!

A hot engine cooling system is dangerous. You or others could be badly burned by steam or boiling coolant. You may want to call an authorized dealer for service if your vehicle overheats. If you decide to look under the hood yourself, see "Maintaining Your Vehicle". Follow the warnings under the Cooling System Pressure Cap paragraph.

CAUTION!

Driving with a hot engine cooling system could damage your vehicle. If the temperature gauge reads "H" pull over and stop the vehicle. Idle the vehicle with the air conditioner turned off until the pointer drops back into the normal range. If the pointer remains on the "H", turn the engine off immediately and call an authorized dealer for service.

WARNING AND INDICATOR LIGHTS

IMPORTANT: The warning / indicator lights switch on in the instrument panel together with a dedicated message and/or acoustic signal when applicable. These indications are indicative and precautionary and as such must not be considered as exhaustive and/or alternative to the information contained in the Owner's Manual, which you are advised to read carefully in all cases. Always refer to the information in this chapter in the event of a failure indication.

All active telltales will display first if applicable. The system check menu may appear different based upon equipment options and current vehicle status. Some telltales are optional and may not appear.

Red Telltale Indicator Lights

Seat Belt Reminder Warning Light

Red Telltale Light	What It Means
	<p>Seat Belt Reminder Warning Light</p> <p>When the ignition is first placed in the ON/RUN position, if the driver's seat belt is unbuckled, a chime will sound and the light will turn on. When driving, if the driver or front passenger seat belt remains unbuckled, the Seat Belt Reminder Light will flash or remain on continuously and a chime will sound. Refer to "Occupant Restraints" in "Things To Know Before Starting Your Vehicle" for further information.</p>

Air Bag Warning Light

Red Telltale Light	What It Means
	<p>Air Bag Warning Light</p> <p>This light will turn on for four to eight seconds as a bulb check when the ignition is placed in the ON/RUN position. If the light is either not on during startup, stays on, or turns on while driving, have the system inspected at an authorized dealer as soon as possible. This light will illuminate with a single chime when a fault with the Air Bag Warning Light has been detected, it will stay on until the fault is cleared. If the light comes on intermittently or remains on while driving, have an authorized dealer service the vehicle immediately.</p>

Brake Warning Light

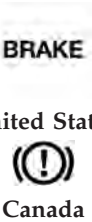
Red Telltale Light	What It Means
 <p data-bbox="147 443 305 466">United States</p>	<p data-bbox="366 253 630 279">Brake Warning Light</p> <p data-bbox="366 284 1548 383">This light monitors various brake functions, including brake fluid level and parking brake application. If the brake light turns on it may indicate that the parking brake is applied, that the brake fluid level is low, or that there is a problem with the anti-lock brake system reservoir.</p> <p data-bbox="366 388 1548 590">If the light remains on when the parking brake has been disengaged, and the fluid level is at the full mark on the master cylinder reservoir, it indicates a possible brake hydraulic system malfunction or that a problem with the Brake Booster has been detected by the Anti-Lock Brake System (ABS) / Electronic Stability Control (ESC) system. In this case, the light will remain on until the condition has been corrected. If the problem is related to the Brake Booster, the ABS pump will run when applying the brake, and a brake pedal pulsation may be felt during each stop.</p> <p data-bbox="366 606 1360 637">NOTE: Brake Warning Light may illuminate due to excessive wear to brake pads.</p>

The dual brake system provides a reserve braking capacity in the event of a failure to a portion of the hydraulic system. A leak in either half of the dual brake system is indicated by the Brake Warning Light, which will turn on when the brake fluid level in the master cylinder has dropped below a specified level.

The light will remain on until the cause is corrected.

NOTE: The light may flash momentarily during sharp cornering maneuvers, which change fluid level conditions. The vehicle should have service performed, and the brake fluid level checked.

If brake failure is indicated, immediate repair is necessary.

WARNING!

Driving a vehicle with the red brake light on is dangerous. Part of the brake system may have failed. It will take longer to stop the vehicle. You could have a collision. Have the vehicle checked immediately.

Vehicles equipped with the Anti-Lock Brake System (ABS) are also equipped with Electronic Brake Force Distribution (EBD). In the event of an EBD failure, the Brake Warning Light will turn on along with the ABS Light. Immediate repair to the ABS system is required.

Operation of the Brake Warning Light can be checked by placing the ignition in the ON/RUN position. The light should illuminate for approximately two seconds. The light should then turn off unless the parking brake is applied or a brake fault is detected. If the light does not illuminate, have the light inspected by an authorized dealer.

The light also will turn on when the parking brake is applied with the ignition placed in the ON/RUN position.

NOTE: This light shows only that the parking brake is applied. It does not show the degree of brake application.

Vehicle Security Warning Light — If Equipped

Red Telltale Light	What It Means
	<p>Vehicle Security Warning Light — If Equipped This light will flash at a fast rate for approximately 15 seconds when the vehicle security alarm is arming, and then will flash slowly until the vehicle is disarmed.</p>

Engine Temperature Warning Light

Red Warning Light	What It Means
	<p>Engine Temperature Warning Light</p> <p>This light warns of an overheated engine condition. As engine coolant temperatures rise and the gauge approaches H, this indicator will illuminate and a single chime will sound after reaching a set threshold. Further overheating will cause a continuous chime sound for 4 minutes, or until the engine is allowed to cool, whichever comes first.</p> <p>If the light turns on while driving, safely pull over and stop the vehicle. If the A/C system is on, turn it off. Also, shift the transmission into NEUTRAL and idle the vehicle. If the temperature reading does not return to normal, turn the engine off immediately and call for service. Refer to “If Your Engine Overheats” in “What To Do In Emergencies” for further information.</p>

Battery Charge Warning Light

Red Telltale Light	What It Means
	<p>Battery Charge Warning Light</p> <p>This light illuminates when the battery is not charging properly. If it stays on while the engine is running, there may be a malfunction with the charging system. Contact your authorized dealer as soon as possible. This indicates a possible problem with the electrical system or a related component.</p>

Oil Pressure Warning Light

Red Telltale Light	What It Means
	<p>Oil Pressure Warning Light</p> <p>This light indicates low engine oil pressure. If the light turns on while driving, stop the vehicle and shut off the engine as soon as possible. A chime will sound when this light turns on. Do not operate the vehicle until the cause is corrected. This light does not indicate how much oil is in the engine. The engine oil level must be checked under the hood.</p>

Electronic Throttle Control (ETC) Warning Light

Red Telltale Light	What It Means
	<p>Electronic Throttle Control (ETC) Warning Light</p> <p>This light informs you of a problem with the Electronic Throttle Control (ETC) system. If a problem is detected while the engine is running, the light will either stay on or flash depending on the nature of the problem. Cycle the ignition key when the vehicle is safely and completely stopped and the transmission is placed in the PARK position. The light should turn off. If the light remains on with the engine running, your vehicle will usually be drivable; however, see an authorized dealer for service as soon as possible.</p> <p>If the light continues to flash when the engine is running, immediate service is required and you may experience reduced performance, an elevated/rough idle, or engine stall and your vehicle may require towing. The light will come on when the ignition is first turned to ON/RUN and remain on briefly as a bulb check. If the light does not come on during starting, have the system checked by an authorized dealer.</p>

Electric Power Steering Fail Warning Light — If Equipped

Red Telltale Light	What It Means
	<p>Electric Power Steering Fail Warning — If Equipped This light is used to manage the electrical warning of the EPS (Electric Power Steering). Refer to “Power Steering” in “Starting And Operating” for further information.</p>

Trailer Brake Disconnected Warning Light

Red Warning Light	What It Means
	<p>Trailer Brake Disconnected Warning Light This telltale is on when the Trailer Brake has been disconnected.</p>

Door Open Warning Light

Red Telltale Light	What It Means
	<p>Door Open Warning Light This indicator will illuminate when a door is open and not fully closed.</p> <p>NOTE: If the vehicle is moving there will also be a single chime.</p>

3

NOTE: Door Open Warning Light will differ depending on the equipped Instrument Cluster Display.

Yellow Telltale Indicator Lights

Engine Check/Malfunction Indicator Light (MIL)

Yellow Telltale Light	What It Means
	<p>Engine Check/Malfunction Indicator Light (MIL)</p> <p>The Engine Check/Malfunction Indicator Light (MIL) is a part of an Onboard Diagnostic System called OBD II that monitors engine and automatic transmission control systems. The light will illuminate when the ignition is in the ON/RUN position before engine start. If the bulb does not come on when turning the key from OFF to ON/RUN, have the condition checked promptly. Certain conditions, such as a loose or missing gas cap, poor quality fuel, etc., may illuminate the light after engine start. The vehicle should be serviced if the light stays on through several typical driving styles. In most situations, the vehicle will drive normally and will not require towing. When the engine is running, the MIL may flash to alert serious conditions that could lead to immediate loss of power or severe catalytic converter damage. The vehicle should be serviced as soon as possible if this occurs.</p>

WARNING!

A malfunctioning catalytic converter, as referenced above, can reach higher temperatures than in normal operating conditions. This can cause a fire if you drive slowly or park over flammable substances such as dry plants, wood, cardboard, etc. This could result in death or serious injury to the driver, occupants or others.

CAUTION!

Prolonged driving with the Malfunction Indicator Light (MIL) on could cause damage to the engine control system. It also could affect fuel economy and driveability. If the MIL is flashing, severe catalytic converter damage and power loss will soon occur. Immediate service is required.

Electronic Stability Control (ESC) Indicator Light — If Equipped

Yellow Telltale Light	What It Means
	<p>Electronic Stability Control (ESC) Indicator Light — If Equipped</p> <p>The “ESC Indicator Light” in the instrument cluster will come on when the ignition is placed in the ON/RUN position, and when ESC is activated. It should go out with the engine running. If the “ESC Indicator Light” comes on continuously with the engine running, a malfunction has been detected in the ESC system. If this light remains on after several ignition cycles, and the vehicle has been driven several miles (kilometers) at speeds greater than 30 MPH (48 km/h), see your authorized dealer as soon as possible to have the problem diagnosed and corrected.</p> <ul style="list-style-type: none"> • The “ESC Off Indicator Light” and the “ESC Indicator Light” come on momentarily each time the ignition is placed in the ON/RUN position. • Each time the ignition is turned to ON/RUN, the ESC system will be ON, even if it was turned off previously. • The ESC system will make buzzing or clicking sounds when it is active. This is normal; the sounds will stop when ESC becomes inactive. • This light will come on when the vehicle is in an ESC event.

Electronic Stability Control (ESC) OFF Indicator Light — If Equipped

Yellow Telltale Light	What It Means
 The icon shows a steering wheel with a car body behind it, and the word "OFF" is printed below the car body.	Electronic Stability Control (ESC) OFF Indicator Light — If Equipped This light indicates the Electronic Stability Control (ESC) is off.

3

Low Washer Fluid Indicator Light — If Equipped

Yellow Telltale Light	What It Means
 The icon shows a windshield with a wiper blade and a reservoir of fluid above it.	Low Washer Fluid Indicator Light — If Equipped This indicator will illuminate when the windshield washer fluid is low.

Tire Pressure Monitoring Indicator Light

Yellow Telltale Light	What It Means
	<p>Tire Pressure Monitoring Indicator Light</p> <p>The warning light switches on and a message is displayed to indicate that the tire pressure is lower than the recommended value and/or that slow pressure loss is occurring. In these cases, optimal tire duration and fuel consumption may not be guaranteed.</p> <p>Should one or more tires be in the condition mentioned above, the display will show the indications corresponding to each tire in sequence.</p>

IMPORTANT: Do not continue driving with one or more flat tires as handling may be compromised. Stop the vehicle, avoiding sharp braking and steering. Repair immediately using the dedicated tire repair kit and contact your authorized dealership as soon as possible.

Each tire, including the spare (if provided), should be checked monthly when cold and inflated to the inflation pressure recommended by the vehicle manufacturer on the vehicle placard or tire inflation pressure label. If your vehicle has tires of a different size than the size indicated on the vehicle placard or tire inflation pressure label, you should determine the proper tire inflation pressure for those tires.

As an added safety feature, your vehicle has been equipped with a Tire Pressure Monitoring System (TPMS) that illuminates a low tire pressure telltale when one or more of your tires is significantly under-inflated. Accordingly, when the low tire pressure telltale illuminates, you should stop and check your tires as soon as possible and inflate them to the proper pressure. Driving on a significantly under-inflated tire causes the tire to overheat and can lead to tire failure. Under-inflation also reduces fuel efficiency and tire tread life, and may affect the vehicle's handling and stopping ability.

Please note that the TPMS is not a substitute for proper tire maintenance, and it is the driver's responsibility to maintain correct tire pressure, even if under-inflation has not reached the level to trigger illumination of the TPMS low tire pressure telltale.

Your vehicle has also been equipped with a TPMS malfunction indicator to indicate when the system is not operating properly. The TPMS malfunction indicator is combined with the low tire pressure telltale. When the system detects a malfunction, the telltale will flash for approximately one minute and then remain continuously illuminated. This sequence will continue upon subsequent vehicle start-ups as long as the malfunction exists. When the malfunction indicator is illuminated, the system may not be able to detect or signal low tire pressure as intended. TPMS malfunctions may occur for a variety of reasons, including the installation of replacement or alternate tires or wheels on the vehicle that prevent the TPMS from functioning properly. Always check the TPMS malfunction telltale after replacing one or more tires or wheels on your vehicle, to ensure that the replacement or alternate tires and wheels allow the TPMS to continue to function properly.

CAUTION!

The TPMS has been optimized for the original equipment tires and wheels. TPMS pressures and warning have been established for the tire size equipped on your vehicle. Undesirable system operation or sensor damage may result when using replacement equipment that is not of the same size, type, and/or style. Aftermarket wheels can cause sensor damage. Using aftermarket tire sealants may cause the Tire Pressure Monitoring System (TPMS) sensor to become inoperable. After using an aftermarket tire sealant it is recommended that you take your vehicle to an authorized dealership to have your sensor function checked.

Low Fuel Indicator Light

Yellow Telltale Light	What It Means
	<p>Low Fuel Indicator Light When the fuel level reaches approximately 3.0 gal (11.0 L) this light will turn on, and remain on until fuel is added.</p>

Anti-Lock Brake (ABS) Indicator Light

Yellow Telltale Light	What It Means
	<p>Anti-Lock Brake (ABS) Indicator Light After the ignition is turned on, the Anti-Lock Brake System (ABS) light illuminates to indicate function check at vehicle startup. If the light remains on after startup or comes on and stays on at road speeds, it may indicate that the ABS has detected a malfunction or has become inoperative. The system reverts to standard non-anti-lock brakes. If both the Brake Warning Light and the ABS Warning Light are on, see an authorized dealer immediately. Refer to “Anti-Lock Brake System” in “Starting And Operating” for further information.</p>

Transmission Temperature Indicator Light

Yellow Telltale Light	What It Means
	<p>Transmission Temperature Indicator Light</p> <p>This light indicates that the transmission fluid temperature is running hot. This may occur with severe usage, such as trailer towing. If this light turns on, safely pull over and stop the vehicle. Then, shift the transmission into NEUTRAL and run the engine at idle or faster until the light turns off.</p>

3

WARNING!

If you continue operating the vehicle when the Transmission Temperature Warning Light is illuminated you could cause the fluid to boil over, come in contact with hot engine or exhaust components and cause a fire.

CAUTION!

Continuous driving with the Transmission Temperature Warning Light illuminated will eventually cause severe transmission damage or transmission failure.

Rear Fog Light Indicator — If Equipped

Yellow Telltale Light	What It Means
	Rear Fog Light Indicator This indicator will illuminate when the rear fog lights are on.

Low Coolant Level Indicator Light

Yellow Telltale Light	What It Means
	Low Coolant Level Indicator Light This telltale will turn on to indicate the vehicle coolant level is low.

Air Suspension Payload Protection Telltale — If Equipped

Yellow Telltale Light	What It Means
	Air Suspension Payload Protection Telltale This telltale will turn on to indicate that the maximum payload may have been exceeded or load leveling cannot be achieved at its current ride height. Protection Mode will automatically be selected in order to “protect” the air suspension system, air suspension adjustment is limited due to payload.

TOW/HAUL Indicator Light

Yellow Telltale Light	What It Means
	TOW/HAUL Indicator Light This light will illuminate when TOW HAUL mode is selected.

3

Cargo Light — If Equipped

Yellow Telltale Light	What It Means
	Cargo Light The cargo light will illuminate when the cargo light is activated by pushing the cargo light button on the headlight switch.

Loose Fuel Filler Cap Indicator Light — If Equipped

Yellow Telltale Light	What It Means
	Loose Fuel Filler Cap Indicator Light — If Equipped This light will illuminate when the fuel filler cap is loose. Properly close the filler cap to disengage the light. If the light does not turn off, please see your authorized dealer.

Air Suspension Off-Road 1 Indicator Light — If Equipped

Yellow Telltale Light	What It Means
	<p>Air Suspension Off-Road 1 Indicator Light This light will illuminate when the air suspension system is set to the Off-Road 1 setting. For further information, refer to “Air Suspension System” in “Starting And Operating”.</p>

Air Suspension Off-Road 2 Indicator Light — If Equipped

Yellow Telltale Light	What It Means
	<p>Air Suspension Off-Road 2 Indicator Light This light will illuminate when the air suspension system is set to the Off-Road 2 setting. For further information, refer to “Air Suspension System” in “Starting And Operating”.</p>

Air Suspension Ride Height Raising Indicator Light— If Equipped

Yellow Telltale Light	What It Means
	<p>Air Suspension Ride Height Raising Indicator Light This light will blink and alert the driver that the vehicle is changing to a higher ride height.</p>

3

Air Suspension Ride Height Lowering Indicator Light— If Equipped

Yellow Telltale Light	What It Means
	<p>Air Suspension Ride Height Lowering Indicator Light This light will blink and alert the driver that the vehicle is changing to a lower ride height.</p>

4WD Indicator Light — If Equipped

Yellow Telltale Light	What It Means
	<p>4WD Indicator Light This light alerts the driver that the vehicle is in the four-wheel drive mode, and the front and rear driveshafts are mechanically locked together forcing the front and rear wheels to rotate at the same speed.</p>

4WD Lock Indicator Light — If Equipped

Yellow Telltale Light	What It Means
	<p>4WD Lock Indicator Light This light alerts the driver that the vehicle is locked in the four-wheel drive mode, and the front and rear driveshafts are mechanically locked together forcing the front and rear wheels to rotate at the same speed.</p>

NEUTRAL Indicator Light — If Equipped

Yellow Telltale Light	What It Means
	<p>NEUTRAL Indicator Light This light alerts the driver that the vehicle is in the NEUTRAL mode and the front and rear driveshafts are disengaged from the powertrain.</p>

4 Low Indicator Light — If Equipped

Yellow Telltale Light	What It Means
	<p>4 Low Indicator Light</p> <p>This light alerts the driver that the vehicle is in the four-wheel drive LOW mode. The front and rear driveshafts are mechanically locked together forcing the front and rear wheels to rotate at the same speed. Low range provides a greater gear reduction ratio to provide increased torque at the wheels.</p> <p>Refer to “Four-Wheel Drive Operation — If Equipped” in “Starting And Operating” for further information on four-wheel drive operation and proper use.</p>

3

Service 4WD Indicator Light — If Equipped

Yellow Telltale Light	What It Means
	<p>Service 4WD Indicator Light</p> <p>If the light stays on or comes on during driving, it means that the 4WD system is not functioning properly and that service is required. We recommend you drive to the nearest service center and have the vehicle serviced immediately.</p>

2WD Indicator Light — If Equipped

Yellow Telltale Light	What It Means
	2WD Indicator Light This light alerts the driver that the vehicle is in the two-wheel drive mode.

Green Telltale Indicator Lights

Park/Headlight ON Indicator Light

Green Telltale Light	What It Means
	Park/Headlight ON Indicator Light This indicator will illuminate when the park lights or headlights are turned on.

Front Fog Indicator Light — If Equipped

Green Telltale Light	What It Means
	Front Fog Indicator Light — If Equipped This indicator will illuminate when the front fog lights are on.

Turn Signal Indicator Lights

Green Telltale Light	What It Means
	<p>Turn Signal Indicator Lights The instrument cluster directional arrow will flash independently for the LEFT or RIGHT turn signal as selected, as well as the exterior turn signal lamp(s) (front and rear) as selected when the multifunction lever is moved down (LEFT) or up (RIGHT).</p> <p>NOTE:</p> <ul style="list-style-type: none"> • A continuous chime will sound if the vehicle is driven more than 1 mile (1.6 km) with either turn signal on. • Check for an inoperative outside light bulb if either indicator flashes at a rapid rate.

3

Cruise Control Set Indicator Light — If Equipped

Green Telltale Light	What It Means
	<p>Cruise Control Set Indicator Light — If Equipped This light will turn on when the electronic speed control has been set.</p>

4WD AUTO Indicator Light — If Equipped

Green Telltale Light	What It Means
	<p>4WD AUTO Indicator Light This light alerts the driver that the vehicle is in the four-wheel drive auto mode, and the front axle is engaged, but the vehicle's power is sent to the rear wheels. Four-wheel drive will be automatically engaged when the vehicle senses a loss of traction. For further information on four-wheel drive operation and proper use, refer to "Four-Wheel Drive Operation — If Equipped" in "Starting And Operating."</p>

White Telltale Indicator Lights**Cruise Control Ready Indicator Light**

White Telltale Light	What It Means
	<p>Cruise Control Ready Indicator Light This light will turn on when the electronic speed control is ON, but not set.</p>

Electronic Speed Control SET Indicator Light — If Equipped

White Telltale Light	What It Means
	<p>Electronic Speed Control SET Indicator Light This light will turn on when the electronic speed control is set. Refer to “Electronic Speed Control” in “Understanding The Features Of Your Vehicle” for further information.</p>

3

Hill Descent Control (HDC) Indicator Light — If Equipped

White Telltale Light	What It Means
	<p>Hill Descent Control (HDC) Indicator Light This indicator will illuminate when Hill Descent Control (HDC) has been selected using the Hill Descent Control Switch. Refer to “Electronic Brake Control” in “Starting And Operating” for further information.</p>

Blue Telltale Indicator Lights

High Beam Indicator Light

Blue Telltale Light	What It Means
	<p>High Beam Indicator Light This indicator shows that the high beam headlights are on. Push the multifunction control lever away from you to switch the headlights to high beam. Pull the lever toward you to switch the headlights back to low beam. Pull the lever toward you for a temporary high beam on, "flash to pass" scenario.</p>

INSTRUMENT CLUSTER DISPLAY

Your vehicle may be equipped with an Instrument Cluster Display, which offers useful information to the driver. With the ignition in the STOP/OFF position (and the key removed, for vehicles with mechanical key), opening/closing of a door will activate the display for viewing, and display the total miles or kilometers in the odometer. Your Instrument Cluster Display is designed to display important information about your vehicle's systems and features.

Using a driver interactive display located on the instrument panel, your Instrument Cluster Display can show you how systems are working and give you warnings when they aren't. The steering wheel mounted controls allow you to scroll through and enter the main menus and submenus. You can access the specific information you want and make selections and adjustments.

Instrument Cluster Display Controls

The Instrument Cluster Display features a driver-interactive display that is located in the instrument cluster.



0409076653

Base Instrument Cluster Display



0409076652

Premium Instrument Cluster Display

The Instrument Cluster Display Menu items may consist of the following:

- Speedometer
- Vehicle Info
- Fuel Economy Info
- Trip A
- Trip B
- Stop/Start Info (If Equipped)
- Air Suspension (If Equipped)

- Audio
- Trailer Tow
- Stored Messages
- Screen Setup
- Vehicle Settings (Not Equipped with a Uconnect 5.0 & 8.4 radio)

The system allows the driver to select information by pushing the following Instrument Cluster Display Control buttons located on the left side of the steering wheel:



040971549

Instrument Cluster Display Control Buttons

- *UP Arrow Button*



Push and release the **UP** arrow button to scroll upward through the main menu items, submenu screen, and vehicle settings.

- *DOWN Arrow Button*



Push and release the **DOWN** arrow button to scroll downward through the main menu items, submenu screen, and vehicle settings.

- *RIGHT Arrow Button*



Push and release the **RIGHT** arrow button to access/select the information screens or submenu screens of a main menu item. Push and hold the **RIGHT** arrow button for two seconds to reset displayed/selected features that can be reset.

- *LEFT Arrow Button*



Push and release the **LEFT** arrow button to access/select the information screens, submenu screens of a main menu item, or to return to the main menu.

Instrument Cluster Display Screens

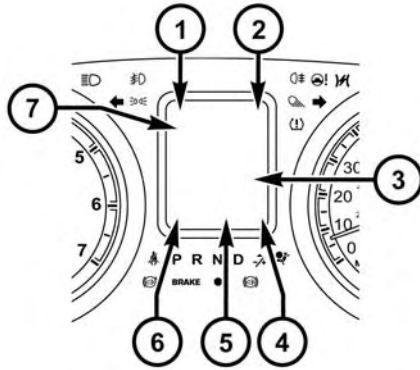

0409021772

Base Instrument Cluster Display

The Instrument Cluster Display Screens are located in the center portion of the cluster and consists of seven sections:

1. *Compass Display*

Displays the current direction. Refer to “Compass Settings” under “Customer Programmable Features — Uconnect 5.0/8.4 Settings” for further information.

2. *Temperature Display*

Displays the temperature in degrees Celsius or degrees Fahrenheit.

3. *Main Screen*

Displays main menu, submenus, settings.

4. *White Telltales*

5. *Amber Telltales*

6. *Red Telltales*

7. *Audio/Phone Information And Submenu Information*

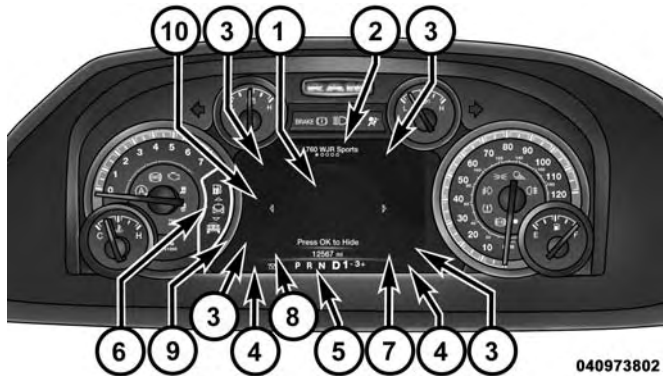

Premium Instrument Cluster Display

The Instrument Cluster Display Screens are located in the center portion of the cluster and consists of eight sections:

1. Main Screen — The inner ring of the display will illuminate in grey under normal conditions, yellow for non critical warnings, red for critical warnings, and white for on demand information.
2. Audio / Phone Information and Submenu Information — Whenever there are sub-menus available, the position within the submenus is shown here.
3. Selectable Information (Compass, Temp, Range to Empty, Trip A, Trip B, Average MPG, Trailer Trip (distance only), Trailer Brake Gain, Time)
4. Telltales/Indicators
5. Gear Selector Status (PRNDL)
6. Selectable Menu Icons
7. Air Suspension Status – If Equipped
8. 4WD Status
9. Selectable Gauge 2 (Trans Temp, Oil Temp, Oil Life, Trailer Brake, Current MPG)
10. Selectable Gauge 1 (Trans Temp, Oil Temp, Oil Life, Trailer Brake, Current MPG)

The Instrument Cluster Display area will normally display the main menu or the screens of a selected feature of the main menu. The main display area also displays “pop up” messages that consist of approximately 60 possible warning or information messages. These pop up messages fall into several categories:

- *Five Second Stored Messages*

When the appropriate conditions occur, this type of message takes control of the main display area for five seconds

and then returns to the previous screen. Most of the messages of this type are then stored (as long as the condition that activated it remains active) and can be reviewed from the “Messages” main menu item. As long as there is a stored message, an “i” will be displayed in the Instrument Cluster Display’s compass/outside temp line. Examples of this message type are “Right Front Turn Signal Lamp Out” and “Low Tire Pressure.”

- *Unstored Messages*

This message type is displayed indefinitely or until the condition that activated the message is cleared. Examples of this message type are “Turn Signal On” (if a turn signal is left on) and “Lights On” (if driver leaves the vehicle).

- *Unstored Messages Until RUN*

These messages deal primarily with the Remote Start feature. This message type is displayed until the ignition is in the RUN state. Examples of this message type are “Remote Start Aborted - Door Ajar” and “Press Brake Pedal and Push Button to Start.”

- *Five Second Unstored Messages*

When the appropriate conditions occur, this type of message takes control of the main display area for five seconds



and then returns to the previous screen. An example of this message type is “Automatic High Beams On.”





Oil Life Reset

Your vehicle is equipped with an engine oil change indicator system. The “Oil Change Required” message will display in the Instrument Cluster Display after a single chime has sounded, to indicate the next scheduled oil change interval. The engine oil change indicator system is duty cycle based, which means the engine oil change interval may fluctuate, dependent upon your personal driving style.







NOTE: Use the steering wheel Instrument Cluster Display controls for the following procedure(s).

Vehicles Equipped With Passive Entry

1. Without pushing the brake pedal, push the ENGINE START/STOP button and place the ignition to the ON/RUN position (do not start the engine).
2. Push and release the **DOWN**  arrow button to scroll downward through the main menu to “Vehicle Info.”
3. Push and release the **RIGHT**  arrow button to access the “Vehicle Info” screen, then scroll up or down to select “Oil Life.”



4. Push and hold the **RIGHT**  arrow button to select "Reset".
5. Push and release the **DOWN**  arrow button to select "Yes," then push and release the **RIGHT**  arrow button to select reset of the Oil Life to 100%.
6. Push and release the **UP**  arrow button to exit the Instrument Cluster Display screen.

Vehicles Not Equipped With Passive Entry



1. Without pushing the brake pedal, cycle the ignition to the ON/RUN position (do not start the engine).
2. Push and release the **DOWN**  arrow button to scroll downward through the main menu to "Vehicle Info."
3. Push and release the **RIGHT**  arrow button to access the "Vehicle Info" screen then scroll up or down to select "Oil Life."
4. Push and hold the **RIGHT**  arrow button to select "YES" by pushing the **RIGHT**  arrow then push and release the **RIGHT**  arrow button to select reset of the Oil Life to 100%.
5. Push and release the **UP**  arrow button to exit the Instrument Cluster Display screen.

NOTE: If the indicator message illuminates when you start the vehicle, the Oil Life indicator system did not reset. If necessary, repeat this procedure.



Instrument Cluster Display Selectable Menu Items

Push and release the **UP**  or **DOWN**  arrow button until the desired Selectable Menu icon is highlighted in the Instrument Cluster Display.

Speedometer

Push and release the **UP**  or **DOWN**  arrow button until the speedometer menu item is highlighted in the Instrument Cluster Display. Push and release the **RIGHT**  arrow button to cycle the display between MPH and km/h.



Vehicle Info

Push and release the **UP**  or **DOWN**  arrow button until the Vehicle Info menu item is highlighted in the Instrument Cluster Display. Push and release the **RIGHT**  arrow button to enter the submenus items of Vehicle Info. follow the directional prompts to access or reset any of the following Vehicle Info submenu items:

- Tire Pressure
- Air Suspension — If Equipped



- Coolant Temp — If Equipped
- Transmission Temp (Automatic only)
- Oil Temp
- Oil Pressure — If Equipped
- Oil Life
- Battery Voltage — If Equipped
- Gauge Summary — If Equipped
- Engine Hours

Fuel Economy

Push and release the **UP**  or **DOWN**  arrow button until the Fuel Economy menu item is highlighted in the Instrument Cluster Display. Push and Hold the **RIGHT**  arrow button to reset Average Fuel Economy.

- Current Fuel Economy Gauge
- Average Fuel Economy value
- Range to Empty



Trip A/Trip B

Push and release the **UP**  or **DOWN**  arrow button until the Trip menu item is highlighted in the Instrument Cluster Display. Push and release the **RIGHT**  arrow button to enter the submenus of Trip A and Trip B. The Trip A or Trip B information will display the following:



- Distance
- Average MPG
- Elapsed Time

Push and hold **RIGHT**  arrow button to reset all information.

Air Suspension — If Equipped



Push and release the **UP**  or **DOWN**  arrow button until the Air Suspension menu item is highlighted in the Instrument Cluster Display. Push and release the **RIGHT**  arrow button to display the Air Suspension status.

Trailer Tow



Push and release the **UP**  or **DOWN**  arrow button until the Trailer Tow menu item is highlighted in the Instrument Cluster Display. Push and release the **RIGHT**  arrow button and the next screen will display the following trailer trip information:

- Trip (trailer specific) Distance: Push and hold the **RIGHT**  arrow button to reset the distance.
- Trailer Brake
 - Output
 - Type
 - Gain

Audio

Push and release the **UP**  or **DOWN**  arrow button until the Audio display icon is highlighted in the Instrument Cluster Display. Push and release the **RIGHT**  arrow button to display the active source.

Screen Setup Menu Item

Push and release the **UP**  or **DOWN**  arrow button until the Screen Setup menu item is highlighted in the Instrument Cluster Display. Push and release the

RIGHT  arrow button to enter the Screen Setup submenu. The Screen Setup feature allows you to change what information is displayed in the instrument cluster as well as the location that information is displayed.

Vehicle Settings Menu Item

Personal Settings allows the driver to set and recall features when the transmission is in PARK.

Push and release the **UP**  and **DOWN**  button until Settings displays in the Instrument Cluster Display.

Follow the prompts to display and set any of the following Vehicle Settings.

NOTE: Your vehicle may be equipped with the following settings.

- If equipped with a base radio (Non-Touchscreen) Vehicle Settings will be included in the Instrument Cluster Display.
- If equipped with a Touchscreen radio, the Vehicle Settings will be included in the radio head unit.

	Setting Names	Setting Names Abbreviated (Left Submenu Layer)	Sub-Menus (Right Submenu Layer)
1	Language Select	Language	English, Spanish, French, Italian, German, Dutch
2	Units	Units	U.S.; Metric
3	ParkSense	ParkSense	<ul style="list-style-type: none"> • Notification — Sound Only; Sound & Display • Front Volume — Low; Medium; High • Rear Volume — Low; Medium; High
4	Tilt Mirror in Reverse	Tilt Mirror in R	On; Off
5	Rain Sensing Wipers	Auto Wipers	On; Off
6	Hill Start Assist	Hill Start Assist	On; Off
7	Headlights Off Delay	Lights Off Delay	0 seconds; 30 seconds; 60 seconds; 90 seconds
8	Illuminated Approach	Lights w/ Unlock	0 seconds; 30 seconds; 60 seconds; 90 seconds
9	Headlights On with Wipers	Lights w/ Wipers	On; Off
10	Automatic Highbeams	Auto Highbeams	On; Off
11	Flash Lights with Lock	Lights w/ Lock	On; Off
12	Auto Lock Doors	Auto Lock Doors	On; Off
13	Auto Unlock Doors	Auto Unlock Doors	On; Off
14	Sound Horn with Remote Start	Horn w/ Rmt Start	On; Off

	Setting Names	Setting Names Abbreviated (Left Submenu Layer)	Sub-Menus (Right Submenu Layer)
15	Sound Horn with Remote Lock	Horn w/ Rmt Lock	Off; 1st Press; 2nd Press
16	Remote Unlock Sequence	Remote Unlock	Driver Door; All Doors
17	Key Fob Linked to Memory	Key in Memory	On; Off
18	Passive Entry	Passive Entry	On; Off
19	Remote Start Comfort System	Rmt Start Comfort	Off; Remote Start; All starts
20	Easy Exit Seat	Easy Exit Seat	On; Off
21	Key-off Power Delay	Power Off Delay	Off; 45 seconds; 5 minutes; 10 minutes
22	Commercial Settings	Commercial	<ul style="list-style-type: none"> • Aux Switches • Power Take-Off • PIN Setup
23	Air Suspension Display Alerts	Air Susp. Alerts	All; Warnings Only
24	Aero Ride Height Mode	Aero Mode	On; Off
25	Tire/Jack Mode	Tire/Jack Mode	On; Off
26	Transport Mode	Transport Mode	On; Off

	Setting Names	Setting Names Abbreviated (Left Submenu Layer)	Sub-Menus (Right Submenu Layer)
27	Wheel Alignment Mode	Wheel Alignment	On; Off
28	Horn w/ Remote Lower	Horn w/ Rmt Lwr	On; Off
29	Lights w/ Remote Lower	Lights w/ Rmt Lwr	On; Off
30	Trailer Select	Trailer Select	Trailer 1; Trailer 2; Trailer 3; Trailer 4
31	Brake Type	Brake Type	Light Electric; Heavy Electric; Light EOH; Heavy EOH
32	Trailer Name	Trailer Name	<ul style="list-style-type: none"> • Trailer # (# is equal to slot position) • Boat • Car • Cargo • Dump • Equipment • Flatbed • Gooseneck • Horse • Livestock • Motorcycle • Snowmobile • Travel • Utility • 5th Wheel

	Setting Names	Setting Names Abbreviated (Left Submenu Layer)	Sub-Menus (Right Submenu Layer)
33	Compass Variance	Compass Var	1-15 increments of 1
34	Calibrate Compass	Compass Cal	Cancel; Calibrate
35	Fuel Saver Display	Fuel Saver	On; Off
36	Park Assist Front Chime Volume	Park Assist Front Chime Volume	On; Off
37	Park Assist Rear Chime Volume	Park Assist Rear Chime Volume	On; Off

Turn Menu OFF — If Equipped

Push and release the **RIGHT**  arrow button to exit the main menu.

Push and release any Instrument Cluster Display control button to enter the Instrument Cluster Display main menu again.

Instrument Cluster Display Messages

- Front Seatbelts Unbuckled
- Driver Seatbelt Unbuckled
- Passenger Seatbelt Unbuckled
- Service Airbag System
- Traction Control Off
- Washer Fluid Low
- Oil Pressure Low
- Oil Change Due
- Fuel Low
- Service Antilock Brake System
- Service Electronic Throttle Control
- Service Power Steering

- Cruise Off
- Cruise Ready
- Cruise Set To XXX MPH
- Tire Pressure Screen With Low Tire(s) “Inflate Tire to XX”
- Tire Pressure Information System (TPIS)
- Service Tire Pressure System
- Parking Brake Engaged
- Brake Fluid Low
- Service Electronic Braking System
- Engine Temperature Hot
- Battery Voltage Low
- Service Electronic Throttle Control
- Lights On
- Right Turn Signal Light Out
- Left Turn Signal Light Out
- Turn Signal On
- Sound Horn with Remote Lock: Off; 1st Press; 2nd Press
- Vehicle Not in Park
- Key in Ignition
- Key in Ignition Lights On
- Remote Start Active Key to Run
- Remote Start Active Push Start Button
- Remote Start Aborted Fuel Low
- Remote Start Aborted Too Cold
- Remote Start Aborted Door Open
- Remote Start Aborted Hood Open
- Remote Start Aborted Trunk Open
- Remote Start Aborted Time Expired
- Remote Start Disabled Start to Reset
- Service Airbag System
- Service Airbag Warning Light
- Driver Seatbelt Unbuckled
- Passenger Seatbelt Unbuckled

- Front Seatbelts Unbuckled
- Door Open
- Doors Open
- Gear Not Available
- Shift Not Allowed
- Shift to Neutral then Drive or Reverse
- Autostick Unavailable Service Required
- Automatic Unavailable Use Autostick Service Req.
- Transmission Getting Hot Push Brake
- Trans. Hot Stop Safely Shift to Park Wait to Cool
- Transmission Cool Ready to Drive
- Trailer Brake Disconnected
- Service Transmission
- Service Shifter
- Engage Park Brake to Prevent Rolling
- Transmission Too cold Idle with Engine On
- Washer Fluid Low
- Service Air Suspension System
- Heavy Duty Air Suspension System Disabled
- Selected Ride Height Not Permitted Due To Speed
- Selected Ride Height Not Permitted Due To Payload
- Selected Ride Height Not Permitted - Payload Too Light
- Battery Low Start Engine To Change Ride Height
- Normal Ride Height Achieved
- Aerodynamic Ride Height Achieved
- Off Road 1 Ride Height Achieved
- Off Road 2 Ride Height Achieved
- Entry/Exit Ride Height Achieved
- Selected Ride Height Not Permitted
- Service Air Suspension System Immediately
- Reduce Speed To Maintain Selected Ride Height
- Air Suspension System Cooling Down Please Wait
- Vehicle Cannot Be Lowered Door Open
- Off Road 2 Watch For Clearance

- Entry/Exit Watch For Clearance
- Air Suspension Temporarily Disabled For Jacking And Tire Change
- Battery Low Start Engine To Change Ride Height

The Reconfigurable Telltales section is divided into the white telltales area on the right, yellow telltales in the middle, and red telltales on the left.

Instrument Cluster Display Controls

The Instrument Cluster Display features a driver-interactive display that is located in the instrument cluster.

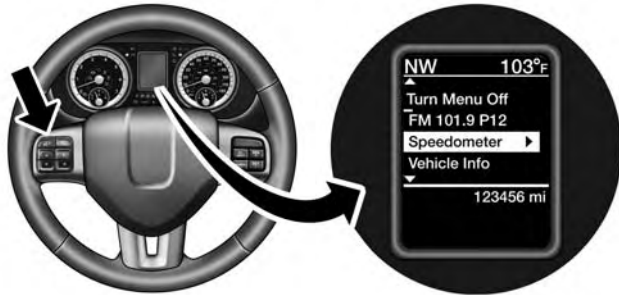

0409076653

Base Instrument Cluster Display



0409076652

Premium Instrument Cluster Display

The Instrument Cluster Display Menu items may consist of the following:

- Speedometer
- Vehicle Info
- Fuel Economy Info
- Trip A
- Trip B
- Stop/Start Info (If Equipped)
- Air Suspension (If Equipped)

- Audio
- Trailer Tow
- Stored Messages
- Screen Setup
- Vehicle Settings (Not Equipped with a Uconnect 5.0 & 8.4 radio)

The system allows the driver to select information by pushing the following Instrument Cluster Display Control buttons located on the left side of the steering wheel:



040971549

Instrument Cluster Display Control Buttons

- *UP Arrow Button*



Push and release the **UP** arrow button to scroll upward through the main menu items, submenu screen, and vehicle settings.

- *DOWN Arrow Button*



Push and release the **DOWN** arrow button to scroll downward through the main menu items, submenu screen, and vehicle settings.

- *RIGHT Arrow Button*



Push and release the **RIGHT** arrow button to access/select the information screens or submenu screens of a main menu item. Push and hold the **RIGHT** arrow button for two seconds to reset displayed/selected features that can be reset.

- *LEFT Arrow Button*



Push and release the **LEFT** arrow button to access/select the information screens, submenu screens of a main menu item, or to return to the main menu.

STARTING AND OPERATING

CONTENTS

■ STARTING PROCEDURES60	■ ADDING FUEL60
■ FUEL REQUIREMENTS60	□ Adding Compressed Natural Gas (CNG)62
□ United States60	■ TRAILER TOWING63
□ Canada60		

STARTING PROCEDURES

Your vehicle uses the same starting procedures as described in the Ram 1500/2500/3500 Owner's Manual. No special starting instructions are required.

NOTE: Periodically the vehicle will automatically switch from operation on CNG to Gasoline for a short duration, depending on conditions. This is done for a number of reasons, including to maintain the freshness and appropriate seasonal blend of gasoline, to ensure maintenance of the gasoline injectors and/or to meet high-load demands.

FUEL REQUIREMENTS

United States

Use only natural gas which meets the requirements for gas quality as specified in National Fire Protection Association NFPA52 and American National Standard ANSI/AGA NGV2. Use of natural gas that does not meet these requirements may result in starting and driveability problems and damage to critical fuel system components.

Canada

Use only natural gas which meets the requirements for gas quality as specified in Canadian Standards Association (CSA) B51-M1991 G4.1.2 or SAE J1616. Use of natural gas

that does not meet these requirements may result in starting and driveability problems and damage to critical fuel system components.

ADDING FUEL

1. Open the fuel filler door.

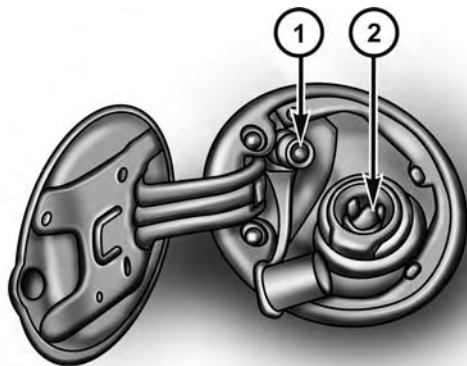

056868459

Fuel Filler Door

- 1 — NGV 1 Receptacle
2 — Gasoline Fuel Filling Receptacle

NOTE: There is no fuel filler cap. A flapper door inside the filler pipe seals the system.

2. Insert the fuel nozzle fully into the filler pipe – the nozzle opens and holds the flapper door while refueling.
3. Fill the vehicle with fuel – when the fuel nozzle “clicks” or shuts off the fuel tank is full.
4. Remove the fuel nozzle and close the fuel door.

Emergency Fuel Can Refueling

Most fuel cans will not open the flapper door.

A funnel is provided to open the flapper door to allow emergency refueling with a fuel can.

1. Retrieve fuel funnel from the jack kit located under the front passenger seat.

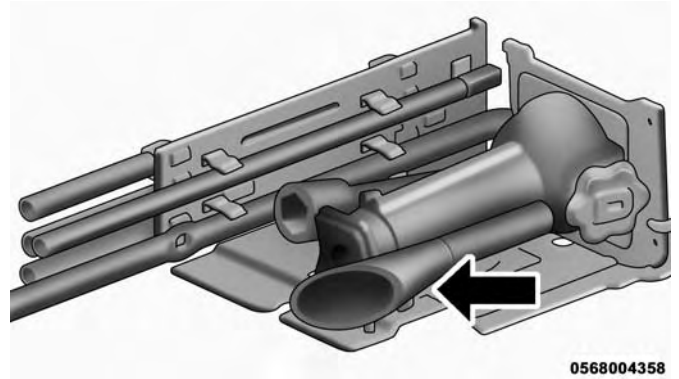

4

Fuel Fill Funnel Location 2500/3500 Models

2. Insert funnel into same filler pipe opening as the fuel nozzle.

NOTE: Ensure funnel is inserted fully to hold flapper door open.

3. Pour fuel into funnel opening.
4. Remove funnel from filler pipe, clean off prior to putting back in the jack kit.

WARNING!

- Never have any smoking materials lit in or near the vehicle when the fuel door is open or the tank is being filled.
- Never add fuel when the engine is running. This is in violation of most state and federal fire regulations and may cause the “Malfunction Indicator Light” to turn on.
- A fire may result if fuel is pumped into a portable container that is inside of a vehicle. You could be burned. Always place fuel containers on the ground while filling.

CAUTION!

To avoid fuel spillage and overfilling, do not “top off” the fuel tank after filling.

Adding Compressed Natural Gas (CNG)

The NGV 1 fuel fill receptacle is mounted in the standard location behind the fuel filler door. The fill dispenser seals to the receptacle with an O-ring. Replace the O-ring in the fill receptacle before refueling if it is damaged or missing; otherwise natural gas can leak while refueling.

Fueling your natural gas powered vehicle can only be performed at locations specially equipped to refuel natural gas vehicles.

NOTE: There are a number of NGV1 filler nozzles available. It may be necessary to rotate the nozzle to ensure clearance to the fuel filler housing or truck bed.

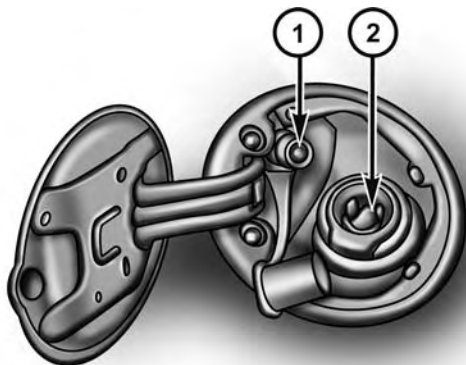

056868459

Fuel Filler Door

- 1 — NGV 1 Receptacle
2 — Gasoline Fuel Filling Receptacle

WARNING!

- Do not attempt to force open or tamper with the fuel fill receptacle. A sudden release of natural gas may occur, possibly causing injury.
- Your vehicle fuel system has a maximum capacity of 3600 pounds per square inch gauge (24.8 MPa) compensated to a temperature of 70°F (21°C). Exceeding the fuel system capacity may result in fuel system damage and possibly cause injury.
- Your vehicle should not be fueled if damage to the container has occurred. The damaged container should be retested and inspected as per the Maintenance section prior to being placed back into service.

NOTE: The fuel containers must be visually inspected every 36 months or 36,000 miles whichever comes first, for damage and deterioration from the date of manufacture. The fuel containers expire and must be removed from service after fifteen years from the date of manufacture. A label on the CNG tank states the first container inspection and container expiration date. Refer to “Maintaining Your Vehicle” in your Owner’s Manual for additional details on retesting.

TRAILER TOWING

NOTE: This vehicle is not compatible with gooseneck/fifth-wheel trailers.

Refer to “Trailer Towing” in “Starting And Operating” in your Owner’s Manual for further information.

MAINTAINING YOUR VEHICLE

CONTENTS

- MAINTENANCE PROCEDURES66
 - Container Pressure, Inspection, And Testing66

MAINTENANCE PROCEDURES

Container Pressure, Inspection, And Testing

Pressure

The vehicle Service Pressure: 24,821 kPa (3,600 psig).

WARNING!

- Do not attempt to force open or tamper with the fuel fill receptacle. A sudden release of natural gas may occur, possibly causing injury.
- Your vehicle fuel system has a maximum capacity of 3600 pounds per square inch gauge (24.8 MPa) compensated to a temperature of 70°F (21°C). Exceeding the fuel system capacity may result in fuel system damage and possibly cause injury.
- Your vehicle should not be fueled if damage to the container has occurred. The damaged container should be retested and inspected as per the Maintenance section prior to being placed back into service.

See instructions on fuel container for inspection and service life.

Inspection

It is recommended that the fuel system components be inspected periodically for leaks and/or excessive wear.

Container Retest Requirements (United States)

Each CNG fuel container must be visually inspected after a motor vehicle accident or fire and at least every 36 months or 36,000 miles, whichever comes first, for damage and deterioration, in accordance with the Federal Motor Vehicle Safety Standard number 304 compressed natural gas fuel containers.

The inspection shall be performed only by a qualified person in accordance with the container manufacturers established re-inspection criteria and the appropriate Compressed Gas Association, Inc. guideline. Retest dates must be marked on a label securely affixed to the container and over-coated with epoxy near the original test date. Reheat treatment or repair of rejected containers is not authorized.

The fuel containers expire and must be removed from service fifteen years from the date of manufacture. A label on the CNG tank states the first container inspection date and container expiration date.

If there is a question about the proper re-inspection of the CNG fuel container, contact the manufacturer as identified on the container label.

Container Retest Requirements (Canada)

Each container must be re-qualified by inspection or testing after a motor vehicle accident and at least every 36 months or 57,000 km whichever comes first, or at the time of any reinstallation in accordance with Canadian Standards Association B51-97, Part 2.

Retest dates must be marked on a label securely affixed to the container and over-coated with epoxy near the original test date. Reheat treatment or repair of rejected containers is not authorized.

The fuel containers expire and must be removed from service fifteen years from the date of manufacture. A label on the fuel container states the first container inspection date and container expiration date.

If there is a question about the proper re-inspection of the CNG fuel container, contact the manufacturer as identified on the container label.

MAINTENANCE SCHEDULE

CONTENTS

■ MAINTENANCE SCHEDULE70
□ Required Maintenance Intervals70

MAINTENANCE SCHEDULE

Required Maintenance Intervals

At Each Stop For Fuel

- Inspect the fuel receptacle O-ring for cracks, tears, and deformation before attaching the fuel station fill line to the fill port.

Every 15,500 Miles (25,000 km)

- Service the fuel receptacle O-ring.

Every 18,000 Miles (30,000 km)

- Replace the CNG high pressure filter element.

Every 36,000 Miles (57,000 km)

- Inspect each CNG fuel container. Each container must be re-qualified and inspected every 36 months or 36,000 miles, whichever comes first.

Refer to “Maintenance Schedules” in your Owner’s Manual for the complete maintenance schedule.

NOTE: All Required Maintenance Intervals are to be performed by certified technicians.

INDEX

- Adding Fuel 60
- Air Bag Light 17
- Alarm (Security Alarm) 19

- Battery 20
 - Charging System Light 20
- Brake System
 - Warning Light 18

- Cruise Light 39, 40, 41

- Door Ajar 23
- Door Ajar Light 23

- Electronic Throttle Control Warning Light 21

- Flashers
 - Turn Signal 39
- Fog Lights 32
- Fuel
 - Adding 60
 - Light 30
- Fueling 60

- Instrument Cluster 20, 39
- Instrument Cluster Display
 - Instrument Cluster Display 42

- Lights
 - Air Bag 17
 - Brake Warning 18
 - Cruise 39, 40, 41
 - Engine Temperature Warning 20
 - Fog 32
 - Low Fuel 30
 - Malfunction Indicator (Check Engine) 24
 - Park 38
 - Seat Belt Reminder 17
 - Security Alarm 19
 - Tire Pressure Monitoring (TPMS) 28
 - Turn Signal 39
 - Warning (Instrument Cluster Description) 20, 39

- Malfunction Indicator Light (Check Engine) 24

- Oil, Engine
 - Pressure Warning Light 21
- Oil Pressure Light 21

Personal Settings50
Programmable Electronic Features50
Seat Belts	
Reminder17
Security Alarm19
Settings, Personal50
Signals, Turn.39
Tires	
Pressure Warning Light28
Turn Signals39

INSTALLATION OF RADIO TRANSMITTING EQUIPMENT

Special design considerations are incorporated into this vehicle's electronic system to provide immunity to radio frequency signals. Mobile two-way radios and telephone equipment must be installed properly by trained personnel. The following must be observed during installation.

The positive power connection should be made directly to the battery and fused as close to the battery as possible. The negative power connection should be made to body sheet metal adjacent to the negative battery connection. This connection should not be fused.

Antennas for two-way radios should be mounted on the roof or the rear area of the vehicle. Care should be used in mounting antennas with magnet bases. Magnets may affect the accuracy or operation of the compass on vehicles so equipped.

The antenna cable should be as short as practical and routed away from the vehicle wiring when possible. Use only fully shielded coaxial cable.

Carefully match the antenna and cable to the radio to ensure a low Standing Wave Ratio (SWR).

Mobile radio equipment with output power greater than normal may require special precautions.

All installations should be checked for possible interference between the communications equipment and the vehicle's electronic systems.



RAM

STICK WITH THE SPECIALISTS®

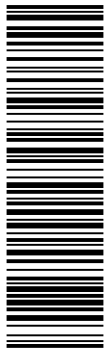

17D241-CNG-AA

©2016 FCA US LLC. ALL RIGHTS RESERVED.

RAM IS A REGISTERED TRADEMARK OF FCA US LLC.



**FIRST EDITION
PRINTED IN U.S.A.**